



그룹개요



그룹연혁



도약

2007 - 현재	2007.01	영성동국 기차배건 유한공사 중국 법인 설립	2013.03	코스모링크 인수
	2007.08	KBI JAPAN 설립	2013.04	MB성산, 갑을메탈로 상호 변경
	2008.02	KB레미콘 설립	2013.09	독일 ICT 인수, KDK 오토모티브 설립
	2008.09	영일특수금속 인수	2014.05	동국실업 신아산공장 준공
	2009.12	모던코리아 인수 (갑을오토텍 상호변경)	2014.08	석문에너지 설립
	2009.12	E좋은중앙병원 인수 (갑을장유병원 상호변경)	2016.01	영일특수금속, 갑을알로이로 상호 변경
	2010.01	갑을의료재단 설립	2016.05	갑을상사그룹 이란지사 설립
	2010.12	MB성산 인수	2017.01	SH-비나 케이블 (코스모링크 베트남 상호변경) 인수
	2011.12	녹산한마음병원 인수 (갑을녹산병원 상호변경)	2017.04	동국멕시코 법인 설립
	2012.01	갑을구미병원 설립	2019.01	KBI그룹 (갑을상사그룹 → KBI그룹)
	2012.12	갑을오토텍 인도 법인 설립	2020.	유상테크 인수, E-Commerce 사업 시작



변화

1996 - 2006	1996.05	한진플라스틱공업 인수 (자동차부품 제조업)	2001.08	동양철관 인수
	1998.11	동국실업 아산 제1공장 준공		



제2의 창업

1986 - 1995	1987.03	갑을합섬 설립	1994.05	동운산업 인수 (KB텍 상호변경)
	1990.09	동국실업 증권거래소 상장	1996.11	국인산업 설립

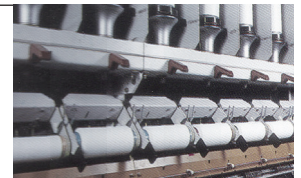

성장

1975 - 1985	1977.01	갑을빌딩 완공
	1978.11	갑을건설 설립



창업

1955 - 1974	1955.12	동국실업 설립	1974.05	갑을 설립
	1956.07	신한견직합명회사 설립		



그룹 계열사 현황



자동차 부품

- KBI 동국실업
- KDK 오토모티브
- KB 오토텍
- KBI 에이스텍
- KBI 모다



소재 / 산업재

- 동양철관
- KBI 메탈
- KBI 코스모링크
- KBI 코스모링크 비나
- KBI 알로이



건설 / 부동산

- KBI 건설
- KB 레미콘
- 갑을상사
- KBI JAPAN



석유 / 제지

- 갑을합섬
- KBI 유상테크



환경 / 에너지

- KBI 국민산업
- KBI 텍
- 석문에너지
- KBI 울트라
- 대구 에코



의료 / E-Commerce

- 갑을의료재단
- 갑을장유병원
- 갑을녹산병원
- 갑을구미병원
- HEUREUX - 핸드백 사업부
- 온라인 사업부



Global Network

JAPAN
CHINA
INDIA
GERMANY
CZECH

KBI Japan
KBI Yancheng Dongkook
KB AutoTech India
KDK Automotive
KDK Automotive

SPAIN
U.A.E.
MEXICO
VIETNAM

KDK Automotive
KB Remicon
KBI Dongkook Mexico
KBI Cosmolink Vina Cable

그룹 경영실적

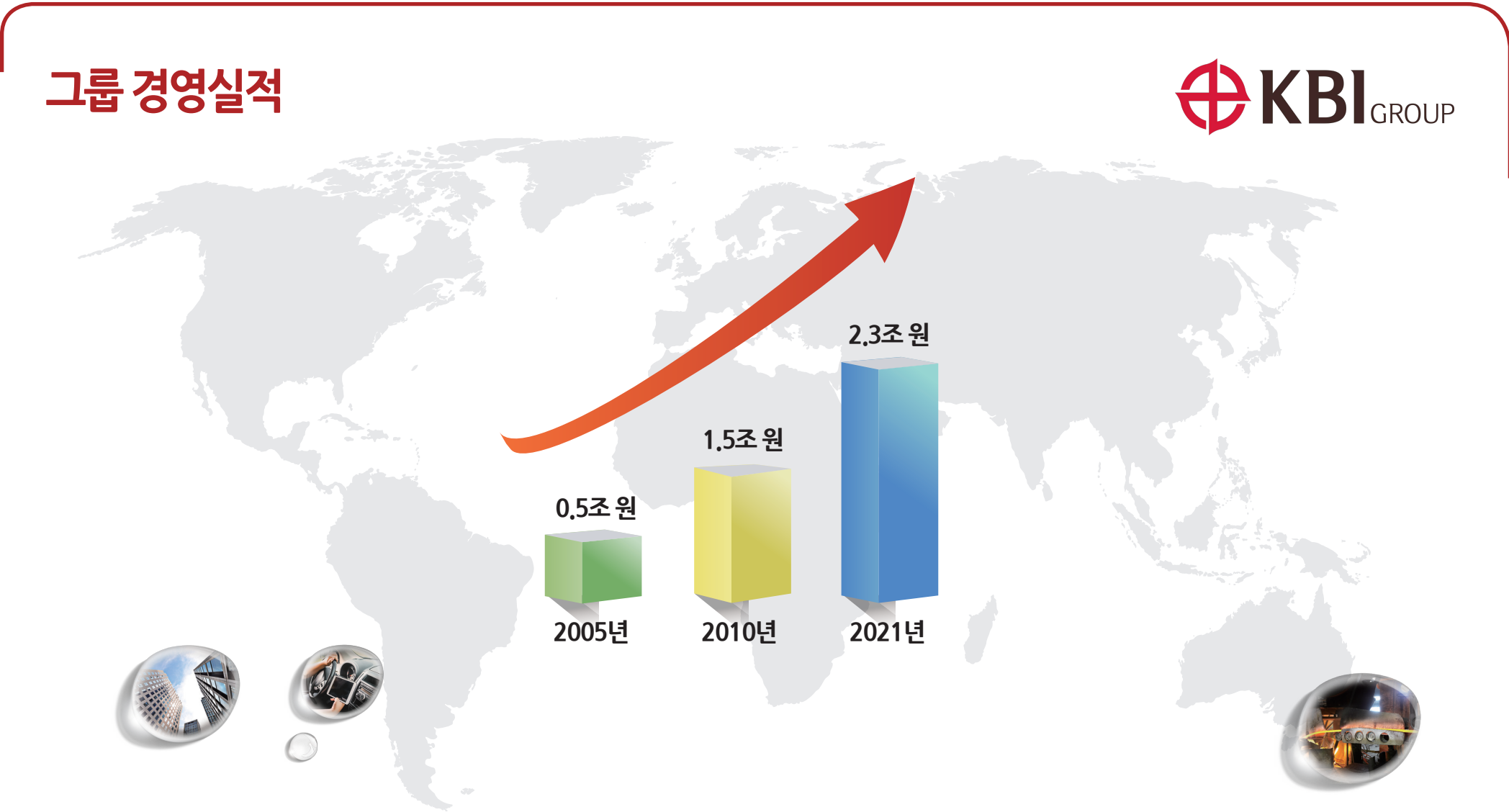

부문별	자동차 부품	소재/산업재	건설/부동산	환경/에너지/의료/섬유	합 계
매출액(2021년 기준)	9,700억 원	9,700억 원	1,000억 원	2,500억 원	2.3 조 원

KBI 동국실업

www.dongkook.net

설립연도: 1955년

매출액: 4,300억 원

종업원수: 2,000여 명



자동차 내외장재 및 공조, 램프 관련부품 제조

국내 사업장

신아산 공장



주요 제품: CRASH PAD MAIN, CONSOLE

아산 공장



주요 제품: GLOVE BOX, LUGGAGE BOARD

울산 공장



주요 제품: CRASH PAD MAIN, GLOVE BOX

경주 공장



주요 제품: LUGGAGE BOARD

해외 사업장

중국 공장 (염성)



주요 제품: CRASH PAD MAIN, LAMP

멕시코 공장 (빠스게리아)



주요 제품: CRASH PAD MAIN, LAMP

주요 고객사



KBI 동국실업

생산 제품 (내장재)



ASSIST HANDLE



CRASH PAD MAIN



CLUSTER FACIA



NOZZLE DEFROSTER



CRASH PAD LWR



GLOVE BOX



CONSOLE



KBI 동국실업

생산 제품 (외장재)



CONNECTION DUCT

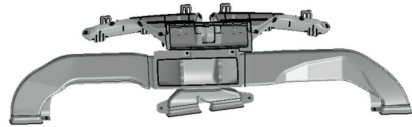

COWL TOP COVER



CARRIER



NOZZLE DEFROSTER



LAMP

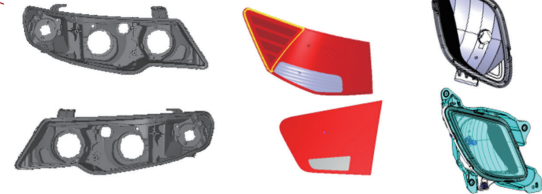

LUGGAGE BOARD

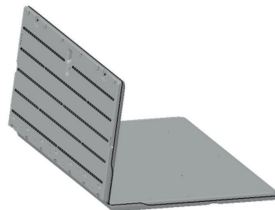

RESERVOIR



KDK 오토모티브

www.kdkautomotive.com

설립연도: 1935년
매출액: 1,500억 원
종업원수: 1,000명



글로벌 자동차 플라스틱 내외장재 부품 제조



사업장

독일 레네슈타트 공장 (본사)



주요 제품: CONSOLE, IMD

독일 베히터스바흐 공장



주요 제품: CONSOLE, PILLAR

체코 타호프 공장



주요 제품: CONSOLE, PILLAR

스페인 보르하 공장



주요 제품: TRIM, DECO

주요 제품

CONSOLE



주요 고객사



KB 오토텍

www.kbautotech.com

설립연도 : 1962년

매 출 액 : 2,000억원

종업원수 : 600명

사 업 장 : 아산, 인도 (첸나이)

자동차 에어컨 시스템 및 열교환기 제품 제조

주요 제품

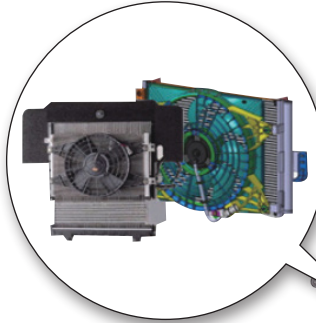

자동차용 에어컨 시스템

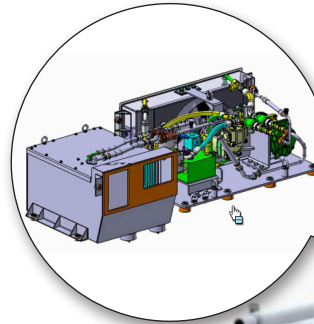

군용장비 (탱크, 장갑차) 에어컨 시스템



열차용 에어컨 시스템



주요 고객사



현대중공업



HYUNDAI
Rotem



Mercedes-Benz

KBI 에이스텍

설립연도: 2013년
매 출 액: 350억원
종업원수: 130명
사 업 장: 아산

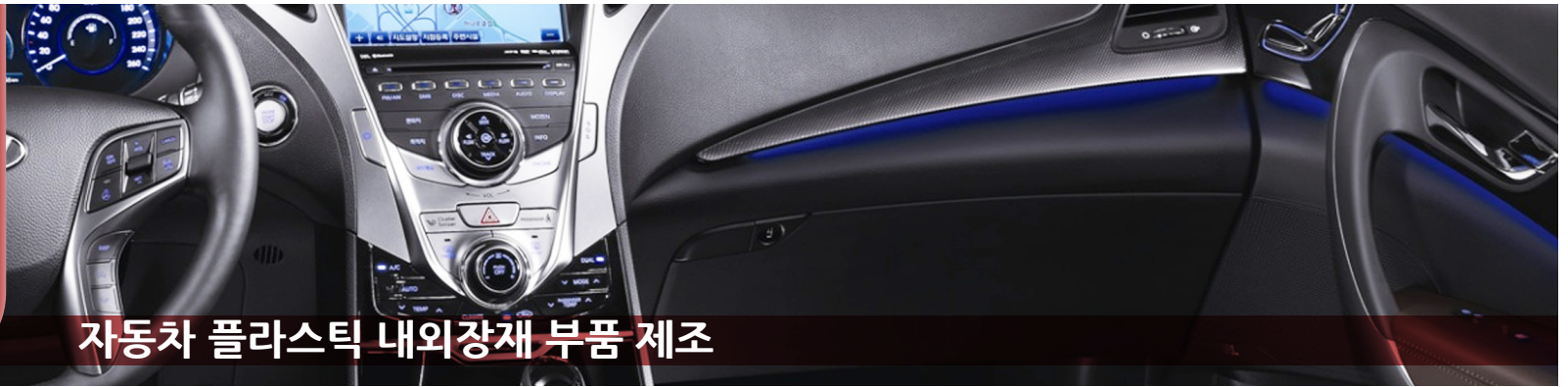

자동차 플라스틱 내외장재 부품 제조

주요 제품



주요 고객사

HYUNDAI
MOBIS

KBI 모다

설립연도 : 2015년
매출액 : 165억 원
종업원수 : 50명
사업장 : 아산



자동차 미션 유회 작용 부품 제조

주요 제품

ATF-WARMER

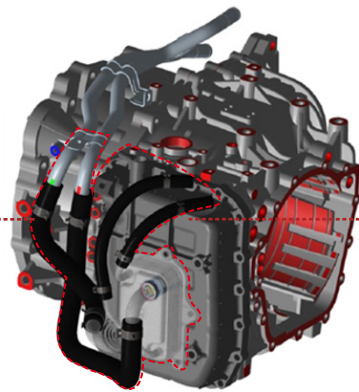
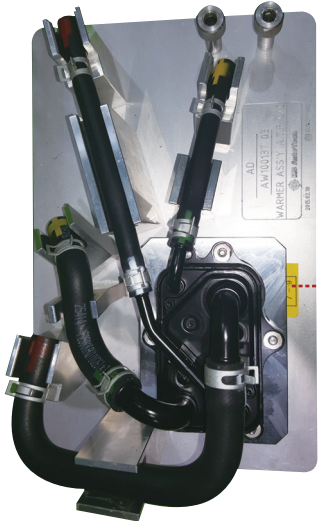

변속기 오일의 온도를 높여 연비개선



동양철관

www.dysp.co.kr

설립연도: 1973년

매출액: 1,500억원

종업원수: 200명

사업장: 서울, 천안, 충주



글로벌 대구경 강관 제조 (수도관, 가스 및 송유관, 구조관, 강관 코팅)

사업장

서울 사무소 (갑을빌딩)



천안 공장



충주 공장



주요 고객사



주요 제품

석유 및 가스수송용 강관



압출식 폴리에틸렌 3층 피복 강관



강관 말뚝



후육 강관



수도용 도복장 강관



상수도용 폴리우레아 도장 강관

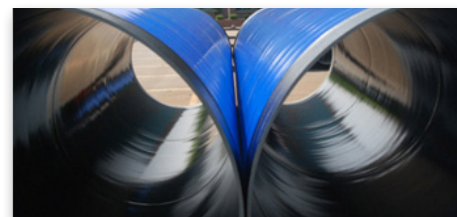

KBI 메탈

www.kbimetal.co.kr

설립연도: 1985년

매출액: 4,800억원

종업원수: 220명

사업장: 서울, 음성, 대구

전선용 구리 ROD (JCR) 및 자동차 전장부품 제조

메탈 사업부

주요 제품

JCR (100% 동스크랩 원료)



주요 고객사



전장 사업부

주요 제품

AC MOTOR

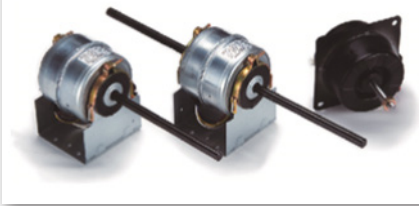

STARTER MOTOR



VENTILATION BOOSTING MODULE



ALTERNATOR



SEAT VENTILATION HEATING MODULE



MOTOR CORE



주요 고객사



BorgWarner



두산인프라코어



KBI 코스모링크

www.cosmolink.co.kr

설립연도: 1965년
매출액: 1,500억원
종업원수: 160명
사업장: 서울, 옥천

종합 전선 (전력선, 통신선, 기기선) 제조

사업장

서울 사무소 (갑을빌딩)



옥천 공장



주요 고객사

 한국전력공사 **SAMSUNG** 아이마켓코리아

주요 제품



절연전선



트레이용 난연 케이블



트레이용 소방용 케이블



저독성 절연전선 및 케이블



22.9kV 전력케이블



가공 송배전, 나동선



3중 절연전선

KBI코스모링크 비나

설립연도 : 2004년
 매출액 : 270억 원
 종업원수 : 90명
 사업장 : 베트남 하노이

베트남 종합 전선 (전력선, 통신선, 기기선) 제조

사업장

하노이 사무소



빈푹 빈옌 공장



주요 고객사

SAMSUNG

POSCO
E&C

VIETNAM ELECTRICITY
EVN
Enlightening Trust

HOA PHAT

주요 제품

BUILDING WIRE



ACSR CABLE



COPPER CABLE



ABC CABLE



AI CABLE



CV, GV CABLE



AV CABLE



COMMUNICATION WIRES

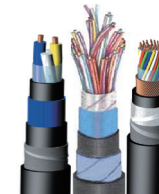

3중 절연전선



INSTRUMENT WIRE



KBI 알로이

www.kbialloy.com

설립연도: 1963년
매출액: 300억 원
종업원수: 70명
사업장: 서울, 아산

특수 동합금 소재 및 부품 제조

주요 제품

전기, 저항, 전극용 소재



자동차 SPOT 용접용 캡팁 및 부품



항공기 전선 소재



주요 고객사



Gadi
Company
Inc.



SCHREIER
METALL



JLOBARA KOREA

KBI 건설

www.kbconst.co.kr

설립연도: 1978년

매출액: 1,200억 원

종업원수: 80명

사업장: 서울

토목 및 건축, 플랜트 분야 건설

주요 사업

도로 건설



서수원-의왕 도로공사

철도 건설



KTX 11-1공구 노반신설

주택 건설



고덕역 갑을 명가시티

교육 시설



도곡 정보문화도서관

업무 시설



가산동 갑을 그레이트 밸리

항만 건설



포항영일만항 남방파제 축조

플랜트



경주 하수처리시설

해외 사업



라오스 GMS 도로개선공사

KB 레미콘

설립연도 : 2008년
매 출 액 : 140억 원
종업원수 : 110명
사 업 장 : U.A.E. 아즈만

콘크리트 제조 및 판매

사업장

U.A.E. 아즈만 사업장



주요 사업

콘크리트 공급



갑을상사

설립연도: 1970년
매 출 액: 100억 원
종업원수: 10명
사 업 장: 서울

국내 부동산 투자 개발 사업

주요 사업

부동산 임대업



갑을상사그룹 사옥 (갑을빌딩)



군포 사업장

KBI JAPAN

www.kbijapan.com

설립연도: 2007년

매출액: 60억원

종업원수: 40명

사업장: 일본

일본 부동산 투자 및 개발 사업

주요 사업

빌딩



산코 빌딩 (일본사무소)

신바시 빌딩

골프장



야부키 골프장



소엔 골프장

SPA



소카 재팬 (전경)



소카 재팬 (내부)

갑을합섬

www.kbsyn.co.kr

설립연도: 1990년
매출액: 510억원
종업원수: 15명
사업장: 서울

직물 원사 유통

주요 제품



- POLY-RAYON
- POLY
- RAYON
- VISCOSE FILAMENT
- POLY-COTTON

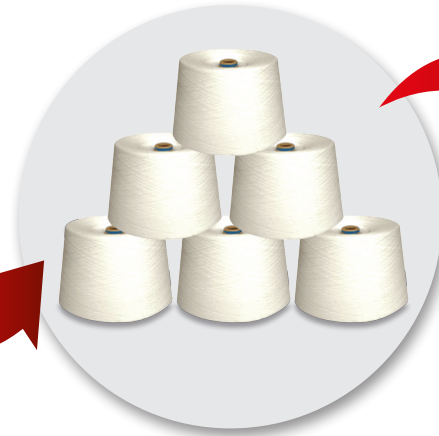

주요 고객사



삼성물산



CHONBANG



일신방직

KBI 국인산업

www.kukin.co.kr

설립연도: 1996년
매출액: 750억 원
종업원수: 70명
사업장: 구미, 군산



국내 최대 규모 폐기물 소각 및 매립

사업장

구미 사업장



군산 사업장



주요 사업

소각 & 스팀



- 업종: 중간처분업 (소각)
열·증기 판매
- 용량: 소각 200톤/일
스팀 25만톤/연
- 품목: 사업자일반, 지정

매립



- 업종: 최종처분업 (매립)
- 용량: 약 690만^m
- 품목: 사업자일반, 지정

주요 고객사

HYOSUNG

삼성코닝정밀유리 **SAMSUNG**

LG 디스플레이

Youngdo Velvet

SK 실트론

KBI 텍

www.ikbtech.c

설립연도: 1982년
매출액: 220억원
종업원수: 45명
사업장: 인천

사업장 · 일반 폐기물 소각 및 신재생 에너지 공급

사업장

인천 사업장 (본사)



주요 사업

소각 & 스팀



- 업종: 중간처분업 (소각)
열 · 증기 판매
- 용량: 소각 150톤/일
스팀 20만톤/연
- 품목: 사업자일반, 지정

주요 고객사

coway
EnTech

청라에너지주식회사

경인양행
KISCO
CREATING COLORS AND CHEMICAL SOLUTIONS

(주)유성화학
YOUSUNG CHEMICAL CO.

폐기물 수집운반



- 업종: 폐기물 수집운반
- 영업구역: 전국

석문에너지

www.smep.co.kr

설립연도: 2013년
매출액: 420억원
종업원수: 50명
사업장: 충남 당진

재생 연료(우드칩)를 사용한 친환경 에너지 공급

사업장

당진 사업장



주요 사업

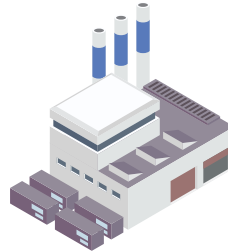

당진화력

수열
→
(2018년 시작)



석문열병합발전소

증기·열 판매
→
(총 열부하 84%)

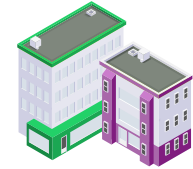

산업단지

전력 판매
←
(2016년 시작)

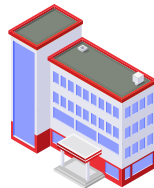

전력거래소

열 판매
→
(총 열부하 16%)



주거단지

재생 연료(우드칩)



주요 고객사



갑을의료재단

www.kbhospital.com

매 출 액 : 550억 원

종업원수 : 450명

사 업 장 : 김해, 부산, 구미



지역 사회에 최상의 의료서비스 제공

사업장

김해시 장유지역의 유일한 종합병원



갑을장유병원

2006년 설립
경남 김해시 장유면 장유로 167-13

공단지역 보건대행 및 특수검진 특화



갑을녹산병원

2011년 설립
부산시 강서구 녹산산단 321로 24-8

급성기 재활치료 및 간호간병통합 서비스



갑을구미병원

2012년 설립
경북 구미시 3공단 1로 280-3



국내 4대 대학병원
진료하이라인 체결



SNUH
서울대학교병원

SAMSUNG
삼성서울병원



세브란스병원
SEVERANCE HOSPITAL

Global Network

